

# HT910 G Terminal User Manual

Revision 1.2



## Important information

This technical description contains important information for start up and use of the HT910 G Terminal. Read it carefully before you start working with the HT910 G Terminal.

The warranty will be void should damage occur due to non-compliance with these instructions for use. We cannot accept any responsibility for consequential loss.

We cannot be held responsible for material loss or personal injury that is due to incompetent use or non-compliance with the safety instructions. The warranty will be void in such circumstances.

The HT910 G Terminal contains highly integrated components which can be damaged by electrostatic discharge if the user would open the housing.

CEP preserves the right to change the included information without notice and doesn't take responsibility for errors in the document and/or missing information.

	Therefore only touch the HT910 G Terminal on the housing or connectors and avoid touching the components on the board.
--	--

## Safety Instructions

	When using products which are exposed to electric voltage the valid regulations have to be observed.
---	--

Before opening of a device always pull the mains adapter or make sure that the device is disconnected from the power supply.

You should only use tools on components, modules or devices if they are disconnected from the power supply and the electric charge, which may still be stored in some components, inside the device has been discharged.

All cables and wires which are energized and connected to the device, the module or components have to be checked regularly for any damage of the isolation shield or fractures of the cables. If the supply cables are visibly damaged the device has to be taken out of operation immediately until the faulty cable has been exchanged.

When using components or modules it is necessary to strictly observe the specification given in the corresponding description of these components. If a description for a private end-customer not clearly states which electric data is valid for a component or a module, how to wire the device, which external components or additional devices can be connected or which parameters these components are allowed to have, a specialist must be contacted.

Before putting a device into operation, it has to be clarified, whether this device or module is meant for the field of application. In case of doubt ask specialists or the manufacturer of the device.

Please note that we are not responsible for any errors in usage or connection. Therefore we cannot accept any responsibility for consequential loss.

Devices which operate with >35 Volt have to be connected by a specialist. Before putting the device into operation it should be checked that there is no current leakage on the housing.

In case those measurements with the opened housing are necessary, an isolating-transformer has to be integrated for safety reasons. Alternatively the voltage can be supplied by an appropriate power supply which complies with the safety regulations. All wiring work has to be done in a voltage free state only.

# Table of Contents

---

Important information.....	2
Safety Instructions.....	2
1 Mechanical Description .....	7
1.1 Overview .....	7
1.2 Physical Dimension and Weight.....	8
2 Electrical Description .....	9
2.1 Power Connector .....	9
2.1.1 Analog Input.....	10
2.1.2 Digital Output .....	11
2.2 Mini USB Connector .....	11
2.3 Antenna Connector .....	12
2.4 SIM card reader.....	13
2.5 RS232 Serial Port.....	13
2.5.1 Serial Data .....	13
2.5.2 Serial Data Signals .....	13
2.5.3 Control Signals – RTS, CTS, DTR, DSR .....	14
3 Operation .....	15
3.1 Switching ON the modem.....	15
3.2 Switching OFF the modem.....	16
3.3 Optional Low Power Mode .....	16
3.4 Operating states / LEDs .....	16
3.4.1 Power up LED (green LED in the middle) .....	16
3.4.2 Status LEDs (one yellow, one red).....	16
3.5 Safety instructions .....	17
3.6 General precautions .....	17
3.7 SIM card precautions .....	18
3.8 Antenna precautions .....	18
4 Installation of the modem .....	19
4.1 Where to install the modem.....	19
4.1.1 Environmental conditions.....	19
4.1.2 GSM Signal strength.....	19
4.1.3 Connections of components to HT910 Terminal .....	19

4.1.4	Network and subscription .....	20
4.2	How to install the modem.....	20
4.2.1	Power supply .....	20
4.2.2	Securing the modem .....	20
4.3	Antenna.....	20
4.3.1	General .....	20
4.3.2	Antenna type.....	21
4.3.3	Antenna placement .....	21
4.3.4	The antenna cable .....	21
4.3.5	Possible communications disturbances .....	22
4.4	CEP Certified Accessories .....	22
5	Technical Data .....	23
6	Abbreviations.....	26
7	Mark of Conformity .....	27
8	Service and Support .....	28
9	Documentation Change Log .....	29

## Table Overview

Table 1: Pin Description .....	10
Table 2: RJ11 Pin and Signals Description .....	10
Table 3: Examples Analog Input.....	11
Table 4: Mini USB Pin description .....	12
Table 5: Recommended characteristics of the serial port signals .....	12
Table 6: Electrical characteristics of the serial port signals.....	13
Table 7: Operating states of the power up LED .....	16
Table 8: Accessoires List .....	22
Table 9: Abbreviation.....	26
Table 10: Documentation Change Log .....	29

## Figure Overview

Figure 1: Connectors on rear side of the Terminal .....	7
Figure 2: Connectors on front side of the Terminal .....	7
Figure 3: Schematic of the Terminal's Housing .....	8
Figure 4: RJ11 Pin Connector.....	9
Figure 5: Mini USB Type A/B connector.....	11



# 1 Mechanical Description

## 1.1 Overview

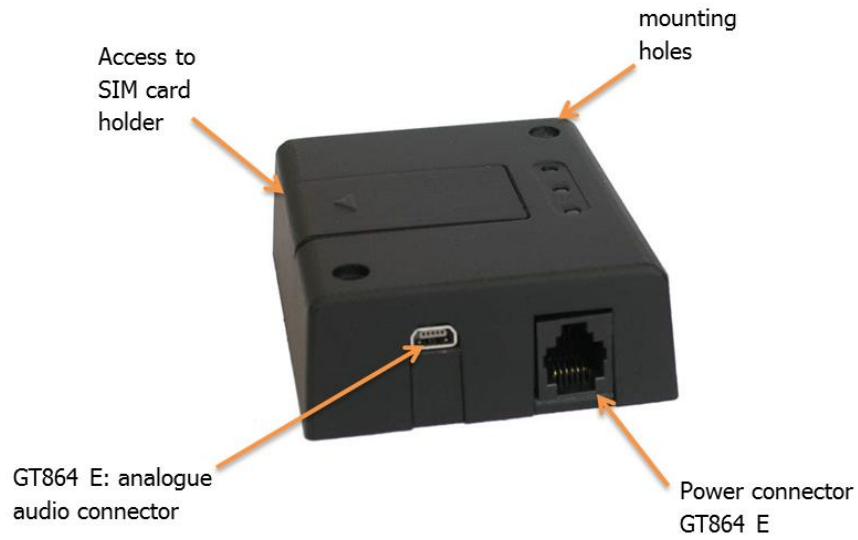

**Figure 1: Connectors on rear side of the Terminal**

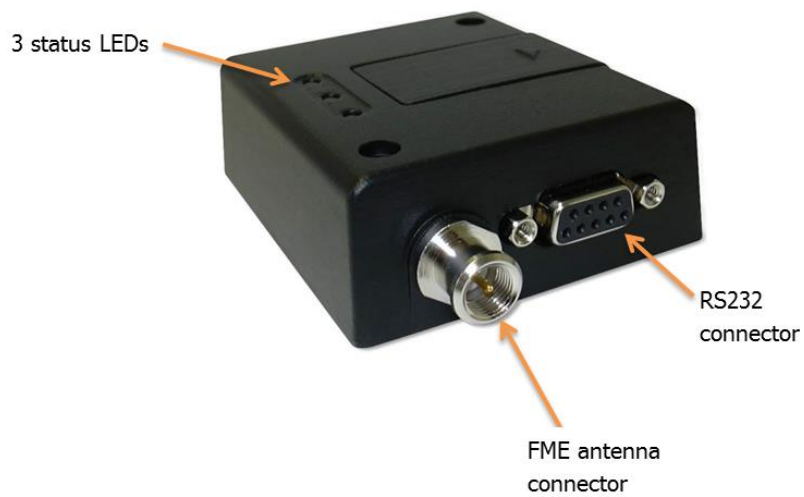

**Figure 2: Connectors on front side of the Terminal**

**Please note the following:**

- Mounting holes positioned at two of the corners make it possible to securely bolt the modem into your application.
- Keypad, display, microphone, speaker and battery are not part of the modem.
- The SIM card is mounted in the modem, accessible by the user under a lid without any tools.
- The pins and electrical characteristics of the modem's various connectors are described in "2. Electrical Description"
- Information about the antenna connector is found in "2.3 Antenna Connector"

## 1.2 Physical Dimension and Weight

Overall dimensions: 77 x 66 x 26 mm

Weight: approx. 90g

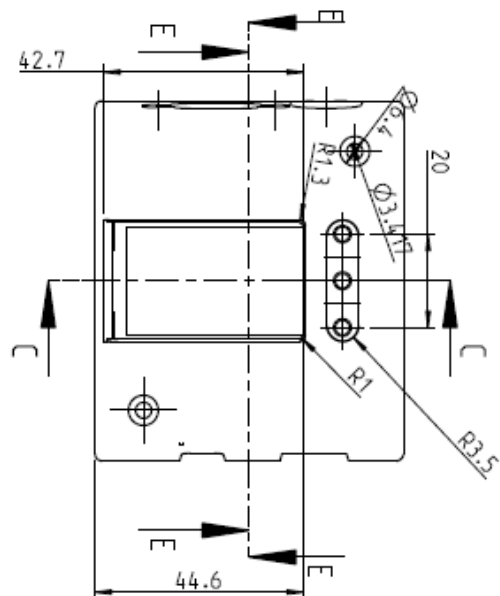
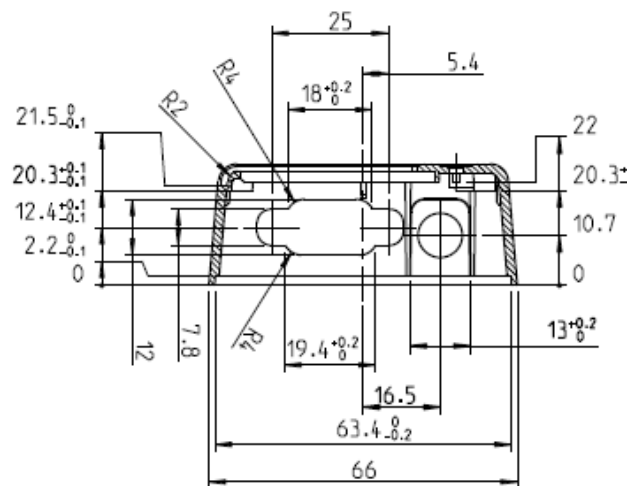
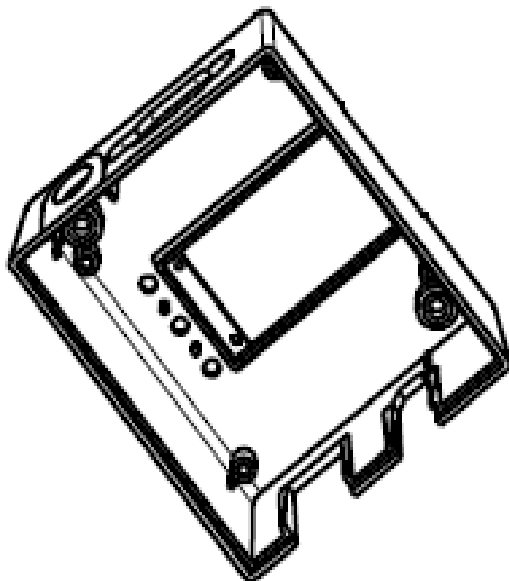
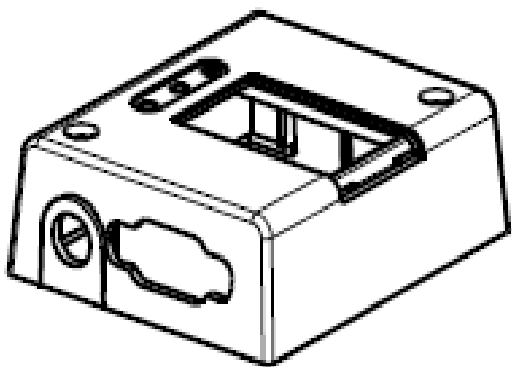

Figure 3: Schematic of the Terminal's Housing



## 2 Electrical Description

The modem uses the following industry standard connectors:

- RJ11 6-way (power/IO connector) – Not connected for USB power variant
- Mini USB (for data) – Also the power connector for USB power variant
- SIM card reader
- FME male coaxial jack (antenna connector)
- Sub-D female socket, 9 pin (RS232 serial port)

### 2.1 Power Connector

An RJ11 6-way connector, as shown and described below, serves as a means of supplying and controlling DC power to the modem.

The supply voltage, VCC, required by the modem is in the range 5V - 32V DC. Application of the supply voltage does not switch the modem on. To do so an additional active-high control signal, TO\_IN, must be applied for > 5 seconds.

Please see chapter “3.1 Switching the modem on” for further important details about TO\_IN and power supply requirements, especially if TO\_IN is applied in parallel to VCC.

VCC and GND are reverse-polarity and over-voltage protected.

	<p>This does not apply for the GND on the antenna connector if this coax GND / shield are connected to your applications ground-plane.</p>
---	--

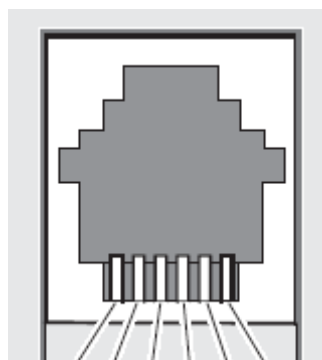

**PIN: 1 2 3 4 5 6**

**Figure 4: RJ11 Pin Connector**

Pin	Description
1	VCC
2	ADC_IN (not applicable in USB Power variant)
3	HR_IN
4	TO_IN
5	optional - DIG_OUT
6	GND

**Table 1: Pin Description**

PIN	Signal	Direction	Limits	Description
1	VCC	Input	5 – 32V	Positive power input, DC
2	ADC_IN or not connected	Input	0 – 32V	- Analogue Input
3	HR_IN	Input	5 – 32V	Active high control line used to switch off $V_{IH} > 5V$ , $V_{IL} < 0.5V$ Power off: $t > 5s$
4	TO_IN	Input	5 – 32V	Positive edge triggered signal; used to switch on the modem $V_{IH} > 5V$ , $V_{IL} < 0.5V$ Power on: $t > 5s$
5	DIG_OUT / or not connected	Output	5 – VCC max. 32V	- optional Digital Output
6	GND	Input	-	Negative power (ground) input and return path for TO_IN and HR_IN

**Table 2: RJ11 Pin and Signals Description**

### 2.1.1 Analog Input

The following command has to be used to initialize and to read the status of the analogue input:

AT#ADC=1,2,0 or AT#ADC=1,2

Response:

#ADC: <digital value> e.g. #ADC: 119

$ADC\_IN \approx 0,03333V \times \text{digital value}$

ADC_IN [V]	5V	12V	24V	32V
digital value	150	360	720	960

**Table 3: Examples Analog Input**

## 2.1.2 Digital Output

- **switched voltage is VIN; high side switch**
- **max. Output 400mA**
- **short circuit protected**
  
- ESD protected
- under full control of embedded application

The following command has to be used to initialize and to set the digital output:

AT#GPIO=6,1,1      output switched on

AT#GPIO=6,0,1      output switched off

## 2.2 Mini USB Connector

There exist two different variants of the terminal module, both in the same housing, and both equipped with the USB-type connector:

- **HT910 Standard**  
The HT910-Standard uses the USB connector for data communication but requires the use of the power connector to power the device.
  
- **HT910 USB Powered**  
The HT910-USB powered variant is be powered directly from the USB connector via a standard 5V USB interface. The RJ11 Power connector is assembled but not connected to anything.

You will find the version of your HT910 on the label on the bottom of the device.

The table below describes the signals on the USB connector.

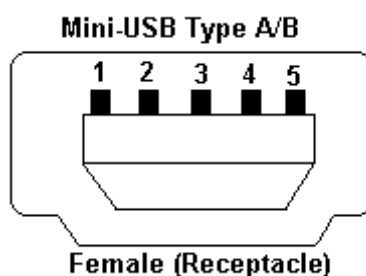

**Figure 5: Mini USB Type A/B connector**

Pin	Signal
1	VUSB
2	D -
3	D +
4	not connected
5	GND

**Table 4: Mini USB Pin description**

### 2.3 Antenna Connector

The antenna connector allows transmission of radio frequency (RF) signals between the modem and an external customer-supplied antenna. The modem is fitted with a 50Ω, FME male coaxial jack.

Output Power:

2 Watt Peak (Class 4)	GSM900/850
1 Watt Peak (Class 1)	GSM1800/1900

The antenna that the customer chooses to use should fulfil the following requirements:

Frequency range	Quad Band GSM 850/900 MHz GSM 1800/1900 MHz Depending by frequency band(s) provided by the network operator, the customer shall use the most suitable antenna for that/those band(s)
Bandwidth	80 MHz in EGSM 900, 70 MHz if GSM 850, 170 MHz in DCS, 140 MHz PCS band
Gain	> 1.5 dBi
Impedance	50 ohm
Input power	> 2 W peak power
VSWR absolute max.	10:1
VSWR recommended	<= 2:1

**Table 5: Recommended characteristics of the serial port signals**

## 2.4 SIM card reader

The HT910 Terminal is fitted with a SIM card reader designed for 3V SIM cards. It is the flip-up type which is lockable in the horizontal position and is accessed through a removable panel.

## 2.5 RS232 Serial Port

The modem supports a standard RS232 serial interface (EIA/TIA 574) via its 9 pin Sub-D connector, shown below. In line with serial communication terminology the HT910 Terminal should be considered as the data circuit-terminating equipment (DCE) and the external application or computer as the data terminating equipment (DTE). The maximum baud rate to communicate with the HT910 Terminal is 230,4 kbit/s.

PIN	Signal	Direction	Voltage levels	Description
1	DCD	Output	> + 4V <- 4 V	Data carrier detect
2	RD	Output	> + 4V <- 4 V	Received data
3	TD	Input	> + 2,4V < 0.8 V	Transmitted data
4	DTR	Input	> + 4V < 0.8 V	Data terminal ready
5	GND	-	0 V	Ground connection
6	DSR	Output	> + 4V < - 4 V	Data set ready
7	RTS	Input	> + 2,4V < 0.8 V	Request to send
8	CTS	Output	> + 4V < - 4 V	Clear to send
9	RI	Output	> + 4V < - 4 V	Ring indicator

**Table 6: Electrical characteristics of the serial port signals**

### 2.5.1 Serial Data

The modem supports the standard data character format of

- Programmable baud rate
- Auto-configuration mode with auto-baud.

### 2.5.2 Serial Data Signals

#### *Serial Data from Modem (RD)*

RD is an output signal that the modem uses to send data to the application.

### *Serial Data To Modem (TD)*

TD is an input signal, used by the application to send data to the modem.

## **2.5.3 Control Signals – RTS, CTS, DTR, DSR**

### *Request to Send (RTS)*

RTS is used to condition the DCE for data transmission. The default level is high by internal pull up. The exact behaviour of RTS is defined by an AT command. Software or Hardware control can be selected. Hardware flow is the default control. The application must pull RTS low to communicate with the modem. The modem will respond by asserting CTS low, indicating it is ready for communication.

### *Clear To Send (CTS)*

CTS indicate that the DCE is ready to transmit data. The default level is high. You can define the exact behaviour of CTS through an AT command, and can select software or hardware flow control.

### *Data Terminal Ready (DTR)*

DTR indicates that the DTE is ready to transmit and receive data. It also acts as hardware 'hang-up', terminating calls when switched high. The signal is active low. You can define the exact behaviour of DTR with an AT command. The DTR line can also be used to switch on the modem when activated for 0.2 seconds. The DTR line must be deactivated prior to switching off the modem to ensure it switches off (powers down) correctly.

### *Data Set Ready (DSR)*

An active DSR signal is sent from the modem to the application (DTE) to confirm that a communications path has been established. DSR has two modes of operation, settable using the AT commands AT&S.

### *Data Carrier Detect (DCD)*

DCD indicates that the DCE is receiving a valid carrier (data signal) when low. You can define the exact behaviour of DCD with an AT command.

### *Ring Indicator (RI)*

RI indicates that a ringing signal is being received by the DCE when low. You can define the exact behaviour for RI with an AT command.



### 3 Operation

#### 3.1 Switching ON the modem

There are two ways to switch on the modem, once power is applied.

- assert TO\_IN to high level for > 5s
- activate the RS232 control line DTR

The modem is fully operational after 4 seconds. Logging onto a network may take longer than this and is outside the control of the modem. The modem can be configured to start up at the time power is applied by permanently tying power connector signals TO\_IN (pin 4) and VCC (pin 1) together. In this case DTR must be used to switch the modem on again after it has been switched off or reset, while power is still applied.

	DTR must be cycled from low to high.
---	--------------------------------------

	The TO_IN signal requires a positive "edge" (a sharp" signal transition from low to high) to turn the modem on. This transition should be a rising signal from 0V (GND) to VCC, or at least a large fraction of that voltage range, and must be applied at the same time as VCC or after it. Very slow transitions (significantly slower than many milliseconds) or very small transitions (e.g. only few volts instead of 0V to VCC) will not turn on the module (since they are not considered to be a "positive edge").
---	--

Although this will not be an issue in almost all typical applications of the modem, please consider following points:

- Large capacitors in your power supply which will lead to slow leading and falling edges (issue does not apply with modern stabilized switching regulator power-adaptors) AND TO\_IN tied in parallel to VCC (instead of separate dedicated digital signal)
- Slow analogue signals used to assert TO\_IN
- TO\_IN signal not before VCC

All 3 cases above might prevent the modem from recognizing the power-up signal this is no failure of the modem itself, the same would apply to almost any electronic device that provides a separate "power-on" or "reset" signal.

If you are doubt, please

- Use the mains power adapter that is provided by your distributor and is know to work properly with your modem
- Make sure that your signal and system design is according to the above
- Consult our support team that will be more than happy to assist you.

### 3.2 Switching OFF the modem

There are two ways to switch off (power down) the modem as described below:

- use the AT#SHDN command; DTR permanently to low (0,8V)
- HR\_IN to high level for  $t > 5s$

A delay of up to 10s is experienced as the modem logs off the network

### 3.3 Optional Low Power Mode

In addition to turning the device completely off the terminal can be placed into a low power mode while maintaining connectivity. To put the device into this low power mode the DTR line must be set to "low" and the AT command "at+cfun=5" must be issued.

In the low power mode current consumption is approximately 11mA with a 12V supply. Current in normal standby mode is approximately 23mA at 12V

There is an additional optional "low power" variant that is available on a project basis that can achieve 2mA with a 12V supply.

### 3.4 Operating states / LEDs

#### 3.4.1 Power up LED (green LED in the middle)

The modem has a green power up LED, as depicted below, which is used to indicate various operating states. These states are described in the following table.

Operating state of HT910 Terminal	Power up LED state
Device off	Permanently off
net search / not registered /	Fast blinking (period=1s, LED <sub>on</sub> =0,5s)
registered full service	Slow blinking (period=3s, LED <sub>on</sub> =0,3s)
Not registered	Permanently on

**Table 7: Operating states of the power up LED**

#### 3.4.2 Status LEDs (one yellow, one red)

The red and yellow Status LEDs are under control of GPIO1 and GPIO2 of the HT910 modem inside of the Terminal. They can be controlled via at-commands. The default status of these

two LEDs is off. The following commands have to be used to initialise and to configure the GPIOs to control the two LEDs:

Switching on GPIO2	at#gpio=2,1,1
Switching off GPIO2	at#gpio=2,0,1
Switching on GPIO3	at#gpio=3,1,1
Switching off GPIO3	at#gpio=3,0,1

These LEDs can be controlled e.g. by an external microcontroller via at-commands issued to the terminal via the serial RS232 interface. They can be used for signalling any useful status of the external application such as:

- error indication
- status of communication (GPRS, SMS, CSD, etc.)
- status of GSM-network (to simulate GSM LED)
- quality of service

Additional Variants

## **Safety and Product Care**

**Please read the information in this section and the information in “Installation of the Modem”, before starting your integration work!**

### **3.5 Safety instructions**

**PLEASE READ THESE SAFETY INSTRUCTIONS AND KEEP A COPY OF THEM.**

- Always ensure that use of the modem is permitted. The modem may present a hazard if used in proximity to personal medical electronic devices. As a rule, the modem must not be used in hospitals, airports or planes.
- Never use the modem at a gas station, refuelling point, blasting area or in any other environment where explosives may be present.
- Operating the modem close to other electronic devices, such as antennas, television sets, and radios may cause electromagnetic interference.
- This product is intended to be used with the antenna or other radiating element at least 20cm away from any part of the human body. In applications where this rule cannot be applied, the application designer is responsible for providing the SAR measurement test report and declaration.
- You are responsible for observing your country's safety standards, and where applicable, the relevant wiring rules.

### **3.6 General precautions**

The HT910 Terminal as a standalone item is designed for indoor use only. To use outside it must be integrated into a weatherproof enclosure. Do not exceed the environmental and electrical limits as specified in "Technical Data".

- Avoid exposing the modem to lighted cigarettes, naked flames or to extreme hot or cold temperature.
- Never try to dismantle the modem yourself. There are no components inside the modem that can be serviced by the user. If you attempt to dismantle the modem, you may invalidate the warranty.
- The HT910 Terminal must not be installed or located where the surface temperature of the plastic case may exceed 85°C.
- All cables connected to the HT910 Terminal must be secured or clamped, immediately adjacent to the modem's connectors, to provide strain relief and to avoid transmitting excessive vibration to the modem in the installation.
- Ensure the cables, supplying power, audio headset, and input cable to the HT910 Terminal, does not exceed 3 metres.
- To protect power supply cables and meet the fire safety requirements when the unit is powered from a battery or a high current supply, connect a fast 1.25A fuse in line with the positive supply.
- Do not connect any incompatible component or product to the HT910 Terminal.

	CEP AG may refuse warranty claims where evidence of product misuse is found.
--	--

### 3.7 SIM card precautions

Before handling the SIM card in your application, ensure that you are not charged with static electricity. Use proper precautions to avoid electrostatic discharges.

When the SIM card hatch is opened, the SIM card connectors lie exposed under the SIM card holder.

Caution! Do not touch these connectors! If you do, you may release an electrical discharge that could damage the modem or the SIM card.

When designing your application, the SIM card's accessibility should be taken into account. We always recommend that you have the SIM card protected by a PIN code. This will ensure that the SIM card cannot be used by an unauthorized person.

### 3.8 Antenna precautions

If the antenna is to be mounted outside, consider the risk of lightning. Follow the instructions provided by the antenna manufacturer.

- Never connect more than one modem to a single antenna. The modem can be damaged by radio frequency energy from the transmitter of another modem.
- Like any mobile station, the antenna of the modem emits radio frequency energy. To avoid EMI (electromagnetic interference), you must determine whether the application itself, or equipment in the application's proximity, needs further protection against radio emission and the

disturbances it might cause. Protection is secured either by shielding the surrounding electronics or by moving the antenna away from the electronics and the external signals cable.

- The modem and antenna may be damaged if either come into contact with ground potentials other than the one in your application. Beware, ground potential are not always what they appear to be.

## 4 Installation of the modem

This chapter gives you advice and helpful hints on how to integrate the HT910 Terminal into your application from a hardware perspective. Please read the information given in "Safety and Product Care", page 10 and then read the information in this section before starting your integration work.

### 4.1 *Where to install the modem*

There are several conditions which need to be taken into consideration when designing your application as they might affect the modem and its function. They are:

#### 4.1.1 Environmental conditions

The modem must be installed so that the environmental conditions stated in the Technical Data chapter, such as temperature, humidity and vibration are satisfied. Additionally, the electrical specifications in the Technical Data section must not be exceeded.

#### 4.1.2 GSM Signal strength

The modem has to be placed in a way that ensures sufficient GSM signal strength. To improve signal strength, the antenna can be moved to another position. Signal strength may depend on how close the modem is to a radio base station. You must ensure that the location, at which you intend to use the modem, is within the network coverage area. Degradation in signal strength can be the result of a disturbance from another source, for example an electronic device in the immediate vicinity. More information about possible communication disturbances can be found in section 5.3.5.

When an application is completed, you can verify signal strength by issuing the AT command AT+CSQ. See "AT+CSQ Signal Strength".

**Tip!** Before installing the modem, use an ordinary mobile telephone to check a possible location for it. In determining the location for the modem and antenna, you should consider signal strength as well as cable length

#### 4.1.3 Connections of components to HT910 Terminal

The integrator is responsible for the final integrated system. Incorrectly designed or installed, external components may cause radiation limits to be exceeded. For instance, improperly made connections or improperly installed antennas can disturb the network and lead to malfunctions in the modem or equipment.

#### **4.1.4 Network and subscription**

Before your application is used, you must ensure that your chosen network provides the necessary telecommunication services. Contact your service provider to obtain the necessary information.

- If you intend to use SMS in the application, ensure this is included in your (voice) subscription.
- Consider the choice of the supplementary services

### **4.2 How to install the modem**

#### **4.2.1 Power supply**

- Use a high-quality power supply cable with low resistance. This ensures that the voltages at the connector pins are within the allowed range, even during the maximum peak current.
- When the unit is powered from a battery or a high current supply, connect a fast 1.25A fuse in line with the positive supply. This protects the power cabling and modem.

#### **4.2.2 Securing the modem**

Before securing the modem take into account the amount of additional space required for the mating connectors and cables that will be used in the application.

- Where access is restricted, it may be easier to connect all the cables to the modem prior to securing it in the application.
- Securely attach the HT910 Terminal modem to the host application using two 3mm diameter pan-head screws

### **4.3 Antenna**

#### **4.3.1 General**

The antenna is the component in your system that maintains the radio link between the network and the modem. Since the antenna transmits and receives electromagnetic energy, its efficient function will depend on:

- the type of antenna (for example, circular or directional);



- the placement of the antenna;
- communication disturbances in the vicinity in which the antenna operates.

In the sections below, issues concerning antenna type, antenna placement, antenna cable, and possible communication disturbances are addressed. In any event, you should contact your local antenna manufacturer for additional information concerning antenna type, cables, connectors, antenna placement, and the surrounding area. You should also determine whether the antenna needs to be grounded or not. Your local antenna manufacturer might be able to design a special antenna suitable for the application.

### 4.3.2 Antenna type

Make sure that you choose the right type of antenna for the modem. Consider the following requirements:

- the antenna must be designed for the one of the frequency bands in use; please ask your network provider for more information:
  - GSM 850/900/2100 MHz
  - EDGE 850 / 900 / 1800 / 1900 MHz
  - UMTS 850/900/2100 MHz
- the impedance of the antenna and antenna cable must be 50 $\Omega$ ;
- the antenna output-power handling must be a minimum of 2W;
- the VSWR value should be less than 3:1 to avoid any damage to the modem.

### 4.3.3 Antenna placement

The antenna should be placed away from electronic devices or other antennas. The recommended minimum distance between adjacent antennas, operating in a similar radio frequency band, is at least 50cm. If signal strength is weak, it is useful to face a directional antenna at the closest radio base station. This can increase the strength of the signal received by the modem. The modem's peak output power can reach 2W. RF field strength varies with antenna type and distance. At 10cm from the antenna the field strength may be up to 70V/m and at 1m it will have reduced to 7V/m. In general, CE-marked products for residential and commercial areas, and light industry can withstand a minimum of 3V/m.

### 4.3.4 The antenna cable

Use 50 $\Omega$  impedance low-loss cable and high-quality 50 $\Omega$  impedance connectors (frequency range up to 2GHz) to avoid RF losses. Ensure that the antenna cable is as short as possible. The Voltage Standing-Wave Ratio (VSWR) may depend on the effectiveness of the antenna, cable and connectors. In addition, if you use an adapter between the antenna cable and the antenna connector, it is crucial that the antenna cable is a high-quality, low-loss cable. Minimize the use of extension cables, connectors and adapters. Each additional cable, connector or adapter causes a loss of signal power.

### 4.3.5 Possible communications disturbances

Possible communication disturbances include the following:

- **Noise** can be caused by electronic devices and radio transmitters.
- **Path-loss** occurs as the strength of the received signal steadily decreases in proportion to the distance from the transmitter.
- **Shadowing** is a form of environmental attenuation of radio signals caused by hills, buildings, trees or even vehicles. This can be a particular problem inside buildings, especially if the walls are thick and reinforced.
- **Multi-path fading** is a sudden decrease or increase in the signal strength. This is the result of interference caused when direct and reflected signals reach the antenna simultaneously. Surfaces such as buildings, streets, vehicles, etc., can reflect signals.
- **Hand-over** occurs as you move from one cell to another in the GSM network. Your mobile application call is transferred from one cell to the next. Hand-over can briefly interfere with communication and may cause a delay, or at worst, a disruption.

## 4.4 CEP Certified Accessories

Product	Description
Power supply 230V AC / 12 VPC	6pin RJ11 connector
Power cable	6pin RJ11 connector with open ends
Minimag Antenna	FME female, 900/1800 MHz
Stub Antenna	FME female, 900/1800 MHz
Rectangular Antenna	FME female, Quad-band
Roof-mount antenna	FME female waterproof, 900/1800 MHz
RS232 cable	1.5m for PC connection

**Table 8: Accessoires List**

Please contact your distributor or CEP AG for availability or check CEP's webpage [www.cepag.de](http://www.cepag.de).

## 5 Technical Data

### Product features:

- UMTS Power class 3 (24dBm)
- GSM 850/900 Power class 4 (33dBm)
- GSM 1800/1900 Power class 1 (30dBm)
- GSM 850/900 Power class E2 (27dBm)
- GSM 1800/1900 Power class E2 (26dBm)
- Control via AT commands according to GSM 07.05, 07.07 and proprietary Telit
- Serial Port Multiplexer GSM 7.10
- SIM Access Profile
- Supply voltage range: 5 – 32 V/DC
- TCP/IP stack access via AT commands
- Sensitivity:
  - -107 dBm (typ.)@ 850/900 MHz
  - -106 dBm (typ.)@ 1800/1900 MHz
- Overall dimensions (excluding connectors): 77 x 67 x 26mm
- Weight: ca. 90g
- RoHS compliant
- Temperature range
  - -30°C to +80°C (Operational)
  - -40°C to +85°C (Storage temperature)

### Interface

- Sub-D female 9 pin connector for RS232 communication
- RJ11:
  - Power: 5 – 36 Volt / DC (ADC)
  - 1 analogue Input and 1 digital Output (optinal)
- Antenna: 50 Ohm (FME male)
- SIM card reader: 3V interface
- Mini USB Interface

### Approvals:

- Full type approved conforming with R&TTE directive
- CE approval
- FCC approval

### SMS:

- Point-to Point mobile originated and mobile terminated SMS
- Concatenated SMS supported
- SMS cell broadcast
- Text and PDU mode

### Circuit switched data transmission:

- Asynchronous transparent circuit switched Data (CSD) up to 14,4 kbps
- Asynchronous non-transparent circuit switched Data (CSD) up to 9,6 kbps
- V.110

**Data:**

- GPRS Class 12
- EDGE Class 33
  - Max 236.8 kbit/s uplink
  - Max 296 kbit/s downlink
- UMTS 384 kbits uplink/downlink
- HSPA category 6 in uplink and up to category 14 in downlink
  - Uplink HSUPA 5.76Mbit/s
  - Downlink Up to 7.2 Mbit/s
  - (Optional) Penta Band UMTS (HSDPA 21.0Mbit/s)

**Fax:**

- Fax Group 3, class 1

**GSM supplementary:**

- Call forwarding
- Call barring
- Call waiting and hold
- Calling Line Identification Presentation (CLIP)
- Calling Line Identification Restriction (CLIR)
- Unstructured supplementary Services Mobile Originated Data (USSD)
- Closed user group

**Internet Protocol:**

- Embedded TCP/IP stack, including TCP/IP, UDP, SMTP and FTP protocol

**Additional Features:**

- SIM phonebook
- Fixed dialling number (FDN)
- Real time clock
- Network LED support
- IRA character set
- Jamming detection & report

**Python application resources**

- Python script interpreter (allows driving the module "internally" implementing the application code directly in the Python language)
- Memory: 3MB of NV memory for the user scripts and 1.2MB RAM for the Python engine usage
- Over the Air Application SW update

**Telits EASY features:**

- "EASY SCAN" : automatic scan over GSM frequencies (also without SIM card)

**Other features:**

- 3x LED for status indication
- Power Supply voltage measurement via at-command
- Same mounting holes as Sony Ericsson GM29 and GS64Terminal
- Same connector positions as Sony Ericsson GM29 and GS64Terminal



## 6 Abbreviations

Abbreviation	Explanations
CBM	Cell Broadcast Message
CBS	Cell Broadcast Service
CSD	Circuit Switched Data
DCE	Data Circuit Terminating Equipment
DTE	Data Terminal Equipment
DTMF	Dual Tone Multi Frequency
EFR	Enhanced Full Rate
EMC	Electro-Magnetic Compatibility
ETSI	European Telecommunication Standards Institute
FR	Full Rate
GPRS	General Packet Radio Service
GSM	Global System for Mobile Communication
HR	Half Rate
HSCSD	High Speed Circuit Switched Data
ITU-T	International Telecommunication Union - Telecommunications Standardisation Sector
ME	Mobile Equipment
MO	Mobile Originated
MS	Mobile Station
MT	Mobile Terminated
PDU	Protocol Data Unit
RLP	Radio Link Protocol
RF	Radio Frequency
RTC	Real Time Clock
SIM	Subscriber Identity Module
SMS	Short Message Service
TA	Terminal Adapter
TE	Terminal Equipment
TS	Telecom Services

**Table 9: Abbreviation**



## 7 Mark of Conformity

The HT910 Terminal will carry the following certificates:

**CEP**  
Aktiengesellschaft  
Cellulare Produkte

CEP AG  
Cellulare Produkte  
Raiffeisenallee 12b  
82041 Oberhaching  
Telefon 089 / 450292-0  
Telefax 089 / 450292-

### CE Declaration of Conformity

Hereby, we declare that our product **HT910 G** is in conformance with the EU directives / standards:

**DIN EN 55022; VDE 0878-22:2011-12**

„Information technology equipment – Radio disturbance characteristics – Limits and methods of measurement (CISPR 22)“

**DIN EN 55024; VDE 0878-24:2011-09**

„Information technology equipment – Immunity characteristics – Limits and methods of measurement (CISPR 24)“

DIN EN 61000-4-2  
DIN EN 61000-4-3  
DIN EN 61000-4-4  
DIN EN 61000-4-5  
DIN EN 61000-4-6  
DIN EN 61000-4-8  
DIN EN 61000-4-11

Oberhaching, 15<sup>th</sup> October 2013

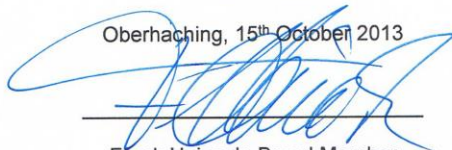

Frank Heineck; Board Member

Our product

**HT910 G**

is based on the GSM/UMTS module HE910-D from the manufacturer Telit Communications S.p.a..

The conformity of the module HE910-G with the essential requirements of the European Directive 1999/5/EC has been verified against the following harmonized standards:

Essential requirements	Specifications / Standards	Submitted documents
Article 3.1(a): Electrical safety	EN 60950-1:2006 + A11:2009 + A12:2011	Test report
Article 3.1(b): EMC	EN 301 489-1 V1.8.1 EN 301 489-3 V1.4.1 <sup>(1)</sup> EN 301 489-7 V1.3.1 EN 301 489-24 V1.5.1	Test report
Article 3.2: Radio spectrum use	EN 300 440-2 V1.4.1 <sup>(1)</sup> EN 301 511 V9.0.2 EN 301 908-1 V4.2.1 EN 301 908-2 V4.2.1	Test report

All AC/DC adapters supplied by CEP AG comply with the standards:

**CE / EN 60950:2009**

CEP AG Cellulare Produkte  
Aufsichtsratsvorsitzende: Dr. Helene Prigge  
Vorstand: Dr. Ditmar Prigge (Vorsitzender)  
Frank Heineck

Hypo Vereinsbank  
BLZ 700 202 70  
Kto. 80 84 1370

Sitz der Gesellschaft: 82041 Oberhaching  
HRB 143723, AG München  
UST-ID: DE813494442

## 8 Service and Support

To contact customer support please use the contact details below:

Customer Support

CEP AG

Raiffeisenallee 12b

82041 Oberhaching

Germany

E-mail: [support@cepag.de](mailto:support@cepag.de)

or

Tel. +49-89-450 292 – 11

Information about CEP AG, products and accessories is available on the following web site:  
<http://www.cepag.de>.

Please contact us via e-mail if you miss anything on the web and we will provide it to you personally via e-mail.



CEP AG may, at any time and without notice, make changes or improvements to the products and services offered and / or cease producing or commercializing them.

## 9 Documentation Change Log

Revision	Date	Changes
Rev 1.0	1.07.2013	Initial Version
Rev. 1.2	21.03.2014	Update Document Layout

**Table 10: Documention Change Log**